

WGOST

Industrial Motors

Commercial &
Appliance Motors

Automation

Digital &
Systems

Energy

Transmission &
Distribution

Coatings

Three-Phase Motor Technical Catalogue



Driving efficiency and sustainability



WGOST

In order to serve the markets that require motors according to the GOST R 51689-2000 (GOST 28330-89) standard, WEG offers the WGOST line, using modern and proven technologies, WEG gives new life to this concept.

High efficiency coupled with low cost of ownership throughout the motor's lifetime have been the basis for the WGOST development. A design created to anticipate concepts in performance and energy savings.

The increasing demand for electrical energy to sustain global development requires consistent heavy investments in power supply generation. However, in addition to complex medium and long term planning, these investments rely on natural resources, which are becoming depleted due to constant pressures upon the environment. The best strategy, therefore, to maintain energy supply in the short term is to avoid wastage and increase energy efficiency.

Electric motors play a major role in this strategy, since around 40% of global energy demand is estimated to be related to electric motor Applications. Consequently, any initiatives to increase energy efficiency, by using high efficiency electric motors and frequency inverters, are to be welcomed, as they can make a real contribution to reductions in global energy demand. At the same time as efficiency initiatives make an impact in traditional market sectors, the application of new technologies in emerging sectors is resulting in profound changes in the way that electric motors are applied and controlled.

By integrating these changes together with the demands for increased energy efficiency, WEG has taken up the challenge and produced a new design of high efficiency motor, one that exceeds the performance of the previous WEG's W21 motor line, which is recognised worldwide for its quality, reliability and efficiency.

Using the latest generation of computerised tools, such as structural analysis software (finite element analysis) and computer fluid dynamics, as well as electrical design optimization software, an innovative - next generation - product has been developed: the WGOST motor.

Several key objectives have been achieved in the design of the WGOST motor:

- Reduction of noise and vibration levels;
- Increased energy efficiency and reduced thermal footprint;
- Easy maintenance;
- Flexible and modular design.



WEG presents to the market a line of general-purpose motors immediately available, whose reliability is present in the dedicated and personalized service. The new line has a complete portfolio of frames (71 to 355M/L) with a sturdy, versatile and efficient design, bringing features that increase the service life and ensure easy maintenance.

WGOST motors, WEG quality for everything your productivity needs.



Lower Total Operational Costs

A product which can operate throughout its lifetime consuming the minimum amount of energy whilst delivering high levels of productivity under continuous operation, without unplanned stops and with optimum performance, thus generating the maximum value to the user - this is the philosophy of the WGOST design.



Energy Efficiency Level

WGOST motors are supplied with IE1 Efficiency Level assuring even greater energy savings and reduced return on investment.



Versatility

The WGOST concept permits the terminal box to be assembled on the top or either side of the motor. For frame sizes 225S/M to 355M/L, a top mounted terminal box can, with the use of an adaptor, be relocated to the left or right side without disassembly of the complete motor, thus reducing modification times and reducing inventories.



Built to Last

WGOST motors are constructed using high quality FC-200 (EN GJL 200) cast iron in WEG's own foundries, assuring maximum durability and high performance in arduous environments. Fan covers were designed to provide greater resistance to impacts, whilst the endshields were developed to maximise bearing heat dissipation.

- Easy installation and maintenance
- Low noise level and vibration severity level B
- Immediately available
- Efficiency level IE1 according to GOST IEC 60034-30-1-2016



Cooling System

Fan Cover

- Aerodynamic concept
- Easier assembly
- Better air flow distribution over frame
- Increased mechanical strength
- Provisions for canopy

Fan

- Reduction of fan blades
- Reinforced fan hub structure
- Noise level reduction
- Increased air flow

Frame

- Terminal box positioned at DE to improve heat dissipation (frames 225S/M to 355M/L)
- Reduced winding and bearing temperatures

Vibration Monitoring

- Flat areas at both ends for placement of accelerometers

Eyebolts

- Safer and easier handling
- High mechanical resistance

Solid Feet

- Higher resistance to impacts
- Suitable for applications with high vibration
- Easier installation and alignment

Endshields Subsystem

DE (Drive Endshield)

- Cooling fins for improved heat dissipation
- Reduced bearing operating temperature
- Reinforced endshield structure
- Bolt protection

NDE (Non-Drive Endshield)

- Designed with smooth surface to improve airflow
- Noise level reduction
- Structure stiffening to avoid machining deformation

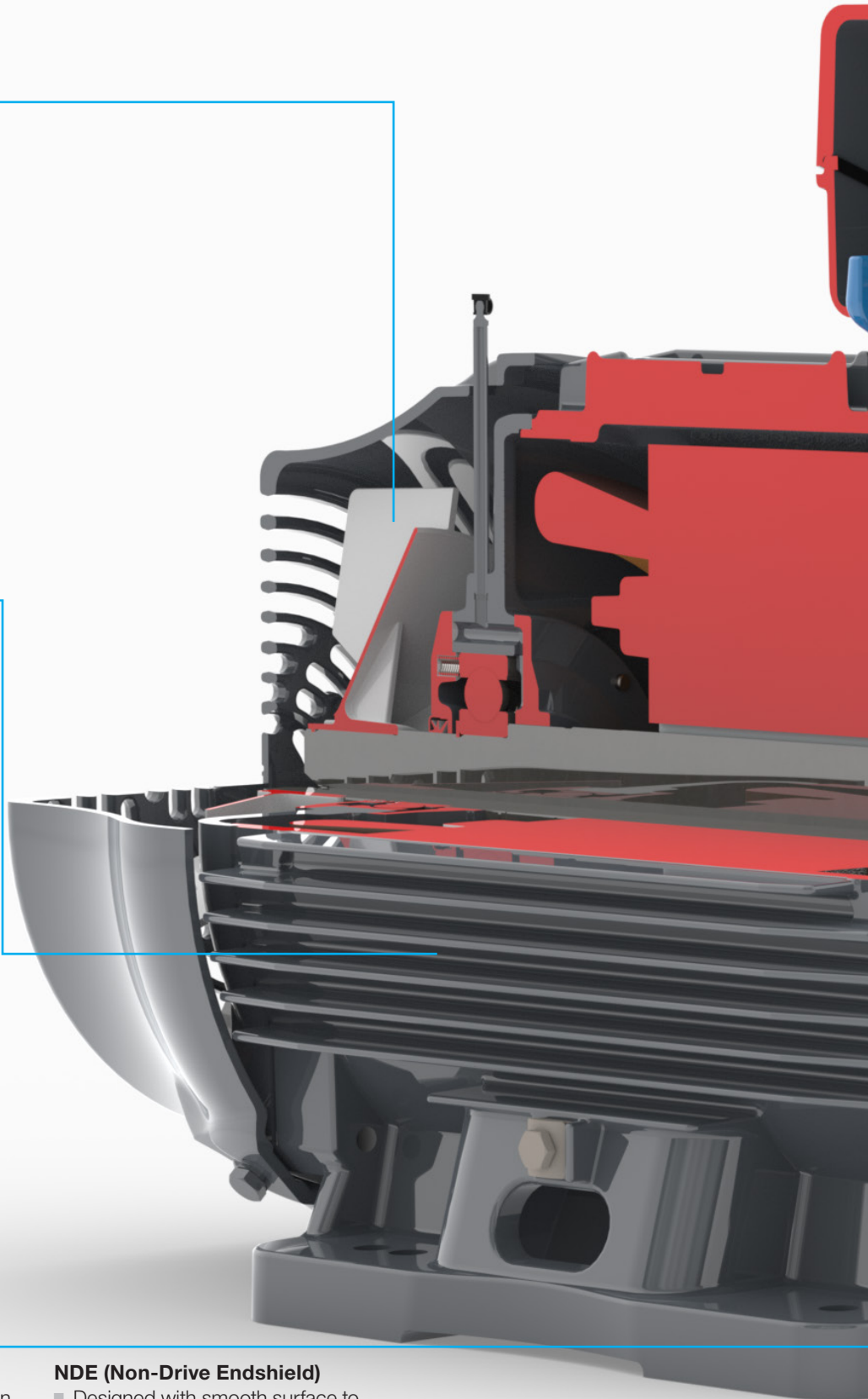

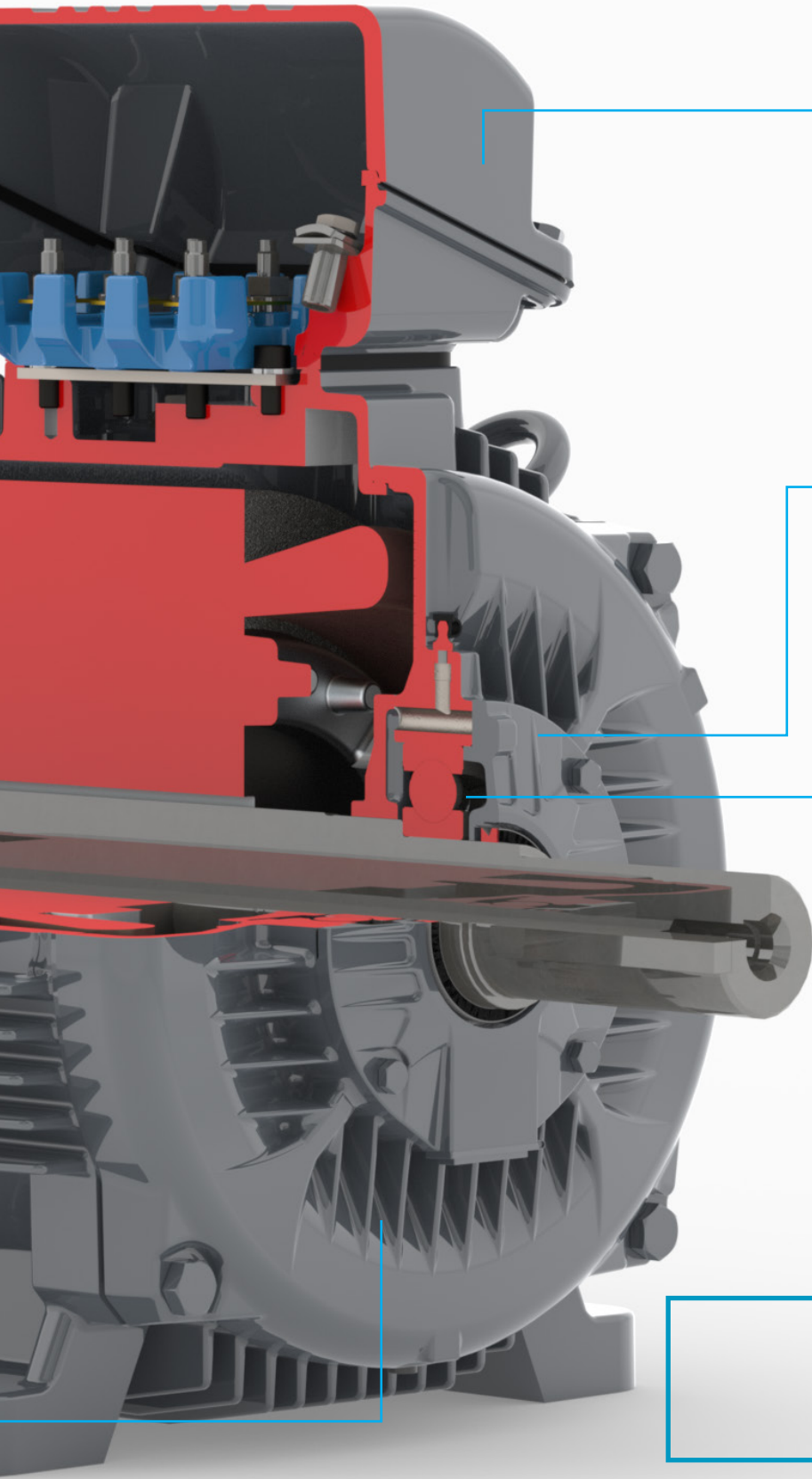

Terminal Box

- Diagonally split for easier cable installation
- More space available for accessory connections
- Flexible mounting (B3T, B3R, B3L) for frames 225S/M to 355M/L
- Rotation 4 x 90°
- Bulk Moulding Compound terminal block (BMC)

Bearing Caps

External

- Finned surface for improved bearing heat dissipation

Internal

- Redesigned grease path
- Improvement in lubrication quality
- Reduced grease operating temperatures

Sealing System

- Increased dust and moisture protection
- V-Ring sealing

3. Construction Details

3.1 Points for Vibration Monitoring

To allow easy maintenance, specifically vibration testing, the 160 to 355 frames are designed with flat areas on both ends for better placement of accelerometers Figure 1). These flat areas are provided in both vertical and horizontal planes.

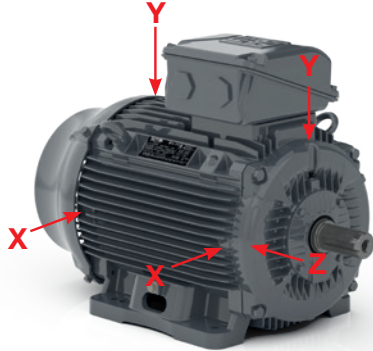

Figure 1 - Flat surfaces for vibration monitoring on the top, front and side.

3.2 Earth Terminals

All frames from 71 to 355M/L are provided with an earth terminal located inside the terminal box (see Figure 2). Motors in frames 225S/M to 355M/L are also fitted with an earth terminal on the frame. It is located on the same side of the main terminal box cable entry (see Figure 2) and is responsible to equalize electrical potential and provide greater safety for operators. Capable of terminating cables from 25 mm² to 185 mm².

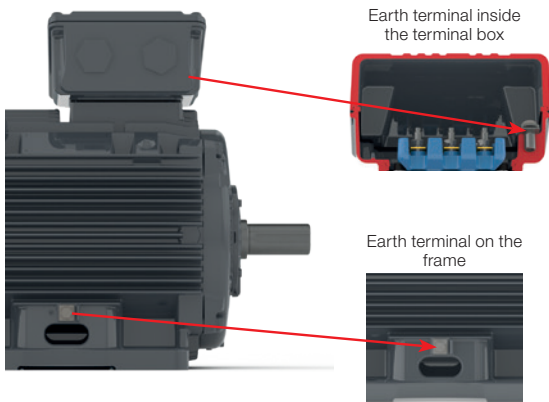

Figure 2 - Earth terminal inside the terminal box and on the frame

Optionally, an external earth terminal can be provided for motors in frame sizes 71 to 200, and, for frame sizes 80 to 355M/L a second external earth terminal as indicated in Figure 3.

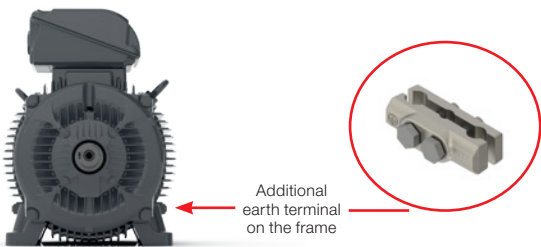

Figure 3 - Additional earth terminal position on the frame.

3.3 Nameplate

The nameplate details information relating to the construction and performance characteristics of the motor. It is also necessary to indicate on the nameplate the IE code and nominal efficiency of the motor at full load (and 3/4 and 1/2 load where space permits), as required by IEC 60034-30-1.

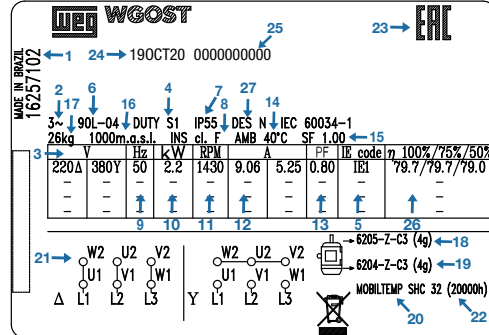

Figure 4 - Nameplate layout for frames 63 to 132

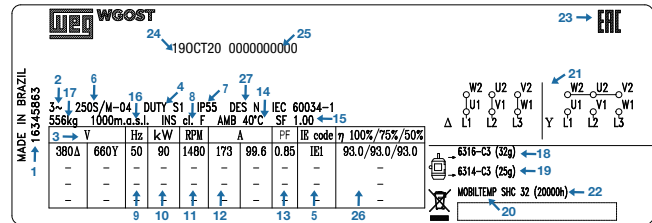

Figure 5 - Nameplate layout for frames 160 to 355

- 1 - Motor code
- 2 - Number of phases
- 3 - Rated operating voltage
- 4 - Service duty
- 5 - Efficiency Code - IE
- 6 - Frame size
- 7 - Degree of protection
- 8 - Insulation class
- 9 - Frequency
- 10 - Motor rated power
- 11 - Full load speed (rpm)
- 12 - Rated operating current
- 13 - Power factor
- 14 - Ambient temperature
- 15 - Service factor
- 16 - Altitude
- 17 - Motor weight
- 18 - Drive end bearing type and amount of grease (where applicable)
- 19 - Non-drive end bearing type and amount of grease (where applicable)
- 20 - Type of grease for bearings
- 21 - Connection diagram
- 22 - Relubrication intervals in hours
- 23 - Certification labels
- 24 - Manufacturing date
- 25 - Serial number
- 26 - Partial load efficiencies
- 27 - Design

3.4 Noise Level

WGOST motors comply with IEC 60034-9 Standard and the corresponding sound pressure levels. Table 1 shows sound pressure levels in dB(A) which are obtained upon tests at 50 Hz.

Frame	IEC 50 Hz Sound pressure level - dB(A) at 1 meter			
	2 poles	4 poles	6 poles	8 poles
71	56	43	-	-
80	59	44	43	42
90	64	49	45	44
100	67	53	44	50
112	64	56	49	46
132	68	60	53	48
160	67	61	57	51
180	67	61	56	52
200	72	65	60	56
225	75	68	63	56
250	75	68	64	56
280	77	71	65	59
315	77	71	67	62
355	80	76	73	70

Table 1 - Sound pressure levels for 50 Hz motors

4. Shaft / Bearings

4.1 Shaft

The shaft steel material for WGOST standard motors is AISI 1040/45, in frames IEC 71 to 315S/M, and AISI 4140 for frame 355M/L. Information regarding the maximum allowable radial and axial loads on shaft ends is given in Table 3 and Table 4. Shafts of WGOST motors are supplied with an open profile keyway, with a threaded centre hole. Dimensions of motor shafts can be found in Section 12 - Mechanical Data.

4.2 Bearings

WGOST motors are supplied with deep groove ball bearings as standard (Figure 6).



Figure 6 - Ball bearing view

The nominal bearing life L10h is 20.000 hours in conformance with maximum radial and axial loads as described in Table 3 and Table 4.

In standard configuration, with ball bearings, the drive end bearing is locked axially from frame 160. To compensate for any axial movement the motors are fitted with pre-load washers for frames 71 to 200 and with pre-load springs for frames 225 to 355.

The lifetime of the bearing is dependent on its type and size, the radial and axial mechanical loads it is submitted to, operating conditions (environment, temperature, mounting orientation), rotational speed and grease life. Therefore, bearing lifetime is closely related to its correct use, maintenance and lubrication. Respecting the quantity of grease and lubrication intervals allows bearings to reach the indicated lifetime. WGOST motors in frames 225S/M and above are provided as standard with grease fittings in each endshield to permit the relubrication of the bearings. The quantity of grease and lubrication intervals are stamped on the motor nameplate.

The lubrication intervals are shown in Table 5. It must be emphasized that excessive lubrication, i.e. a quantity of grease greater than that recommended on the motor nameplate, can result in the increase of bearing temperatures leading to reduced operating hours.

Note:

1. L10h lifetime means that at least 90% of the bearings submitted to the maximum indicated loads will reach the number of hours indicated. The maximum admissible radial and axial loads for the standard configuration are shown in Table 3 and Table 4. The values of the maximum radial load consider axial load as nil. The values of the maximum axial load consider radial load as nil. For bearing lifetimes with combined axial and radial loads condition contact WEG.
2. The radial force value Fr usually results from information recommended in the catalogues of pulley / belt manufacturers. When this information is not available, the force Fr, under operation, can be calculated based on the output power, on coupling design characteristics with pulleys and belts and on the type of application. So we have:

$$Fr = \frac{19,1 \times 10^6 \times P_n}{n_n \times dp} \times ka \text{ (N)}$$

Where:

- Fr is the radial force caused by pulley and belt coupling [N];
- Pn is the motor rated power [kW];
- nn is the motor rated speed per minute [rpm];
- dp is the pitch diameter of the drive pulley [mm];
- ka is a factor that depends on belt tension and type of application (Table 2).

Groups and basic types of application		ka factor of the application	
		V belts	Plane belts
1	Fans and blowers, centrifugal pumps, winding machines, compressors, machine tools with outputs up to 22 kW (30 HP)	2,0	3,1
2	Fans and blowers, centrifugal pumps, winding machines, compressors, machine tools with outputs higher than 22 kW (30 HP)	2,4	3,3
3	Presses, vibrating screens, piston and screw compressors, pulverisers, helicoidal conveyors, woodworking machines, textile machines, kneading machines, ceramic machines, pulp and paper industrial grinders (for all power range).	2,7	3,4
4	Overhead cranes, hammer mills, metal laminators, conveyors, gyratory crushers, jaw crushers, cone crushers, cage mills, ball mills, rubber mixers, mining machines, shredders (for all power range).	3,0	3,7

Table 2 - ka factor

Important:

1 - Special applications

Motor operation under adverse operating conditions, such as higher ambient temperatures and altitudes or abnormal axial / radial loads, may require specific lubrication measures and alternative relubrication intervals to those indicated in the tables provided within this technical catalogue.

2 - Frequency inverter driven motors

Bearing life may be reduced when a motor is driven by a frequency drive at speeds above nominal. Speed itself is one of the factors taken into consideration when determining motor bearing life.

3 - Motors with modified mounting configurations

For motors supplied with horizontal mounting but working vertically, lubrication intervals must be reduced by half.

4 - Figures for radial thrusts

The figures given in the tables below for radial thrusts take into consideration the point upon which the load is applied, either at the centre of the shaft (L/2) or at the end of the shaft (L), Figure 7.

Note: On motors with second shaft end, refer to WEG for details of the maximum permissible axial and radial loads.

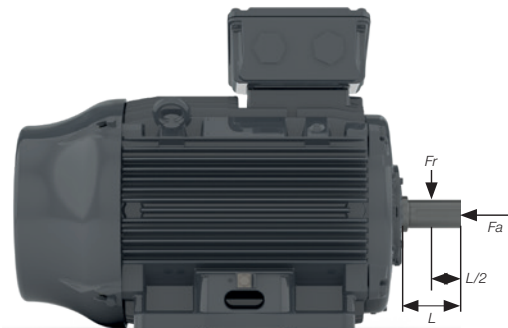

Figure 7 - Radial and axial thrust on motor shaft

4.2.1 Permissible Loads

Radial Thrust - Ball Bearings

Maximum permissible radial thrust - 50 Hz - Fr in (kN) 20.000 hours								
Frame	2 poles		4 poles		6 poles		8 poles	
	L	L/2	L	L/2	L	L/2	L	L/2
71	0,6	0,6	0,7	0,8	0,8	0,9	0,9	1,0
80	0,6	0,6	0,8	0,9	0,9	1,0	1,0	1,1
90	0,6	0,6	0,8	0,9	0,9	1,0	1,0	1,1
100	0,9	1,0	1,1	1,3	1,3	1,4	1,5	1,6
112	1,5	1,7	1,9	2,2	2,2	2,5	2,2	2,8
132	1,9	2,1	2,3	2,6	2,7	3,0	3,1	3,4
160	2,4	2,7	4,1	4,6	4,4	5,3	5,1	5,9
180	3,3	3,6	4,7	5,3	5,4	6,1	6,0	6,7
200	3,9	4,3	6,2	6,9	6,7	8,0	7,0	8,9
225	5,1	5,6	6,2	6,8	6,9	7,8	6,8	8,5
250	5,0	5,5	7,4	8,1	8,5	9,3	9,4	10,3
280	5,9	6,4	8,6	9,5	9,9	10,9	10,9	12,1
315	5,5	5,9	8,1	8,8	9,1	9,9	10,0	10,9
355	4,4	4,7	10,3	11,3	12,1	13,1	8,4	14,3

Table 3 - Maximum permissible radial thrusts for ball bearings (horizontal mounting)

Axial Thrust - Ball Bearings

Maximum permissible axial thrust - 50 Hz - Fa in (kN) - 20.000 hours							
Frame	Poles	Horizontal		Vertical with shaft upwards		Vertical with shaft downwards	
		Pushing	Pulling	Pushing	Pulling	Pushing	Pulling
71	2	0,3	0,3	0,3	0,3	0,3	0,3
	4	0,4	0,5	0,4	0,5	0,4	0,5
	6	0,5	0,7	0,5	0,7	0,5	0,7
	8	0,6	0,8	0,6	0,8	0,6	0,8
80	2	0,4	0,3	0,4	0,4	0,4	0,3
	4	0,5	0,5	0,5	0,6	0,6	0,5
	6	0,6	0,7	0,6	0,8	0,7	0,7
	8	0,7	0,9	0,7	0,9	0,8	0,8
90	2	0,5	0,3	0,5	0,4	0,6	0,3
	4	0,7	0,5	0,6	0,6	0,8	0,5
	6	0,9	0,7	0,8	0,8	0,9	0,6
	8	1,0	0,8	0,9	0,9	1,1	0,8
100	2	0,6	0,5	0,5	0,6	0,7	0,4
	4	0,8	0,8	0,7	0,9	0,9	0,7
	6	0,9	1,0	0,8	1,1	1,1	0,9
	8	1,1	1,2	1,0	1,3	1,2	1,1
112	2	0,8	1,0	0,7	1,2	0,9	1,0
	4	1,1	1,5	1,0	1,7	1,2	1,4
	6	1,3	1,9	1,1	2,1	1,5	1,8
	8	1,5	2,2	1,3	2,4	1,6	2,1
132	2	1,0	1,2	0,8	1,4	1,3	1,0
	4	1,4	1,8	1,1	2,1	1,7	1,5
	6	1,6	2,2	1,4	2,5	2,0	2,0
	8	1,9	2,6	1,6	2,9	2,3	2,3
160	2	2,6	1,7	2,3	2,0	2,9	1,4
	4	4,3	3,2	4,0	3,8	4,9	2,9
	6	5,1	4,0	4,7	4,6	5,7	3,6
	8	5,7	4,6	5,4	5,1	6,2	4,3
180	2	3,3	2,2	3,0	2,7	3,8	1,9
	4	5,0	3,8	4,5	4,4	5,6	3,3
	6	5,8	4,6	5,3	5,4	6,6	4,1
	8	6,5	5,3	6,1	6,2	7,4	4,9
200	2	3,8	2,6	3,2	3,3	4,5	2,0
	4	6,4	5,0	5,7	6,0	7,4	4,3
	6	7,5	6,1	6,8	7,1	8,5	5,4
	8	8,5	7,1	7,7	8,1	9,5	6,3
225	2	4,9	3,5	4,2	4,4	5,8	2,8
	4	6,4	5,0	5,6	6,3	7,7	4,2
	6	7,5	6,1	6,5	7,4	8,8	5,1
	8	8,3	6,9	7,3	8,3	9,7	5,9
250	2	4,8	3,4	3,9	4,8	6,2	2,5
	4	7,2	5,6	6,0	7,5	9,1	4,4
	6	8,4	6,8	7,0	8,6	10,2	5,4
	8	9,5	7,9	8,0	9,9	11,5	6,5
280	2	5,4	3,8	3,8	5,6	7,2	2,2
	4	8,2	6,3	5,9	9,0	10,9	4,0
	6	9,7	7,8	7,3	10,8	12,7	5,4
	8	10,9	9,0	8,3	12,0	13,9	6,4
315	2	5,2	3,6	2,8	6,1	7,7	1,2
	4	7,9	6,0	5,0	9,9	11,8	3,1
	6	9,2	7,3	5,6	11,4	13,3	3,7
	8	10,3	8,4	6,4	13,2	15,1	4,5
355	2	4,6	2,7	1,5	6,9	On request	
	4	9,4	7,2	5,0	12,5	14,7	2,8
	6	11,2	9,0	6,3	14,1	16,3	4,1
	8	12,4	10,2	6,7	15,9	18,1	4,5

Table 4 - Maximum permissible axial thrusts for ball bearings (horizontal mounting).

Lubrication Intervals

Lubrication intervals (hours)			
Frame	Poles	50 Hz	
71	2	20.000	
	4		
	6		
	8		
80	2		
	4		
	6		
	8		
90	2		
	4		
	6		
	8		
100	2		
	4		
	6		
	8		
112	2		
	4		
	6		
	8		
132	2		
	4		
	6		
	8		
160	2		
	4		
	6		
	8		
180	2	9.000	
	4		
	6		20.000
	8		
200	2	9.000	
	4		
	6		20.000
	8		
225	2	7.000	
	4		
	6		18.000
	8		
250	2	7.000	
	4		
	6		18.000
	8		
280	2	7.000	
	4		
	6		18.000
	8		
315	2	6.000	
	4		
	6		14.000
	8		
355	2	6.000	
	4		
	6		14.000
	8		

Table 5 - Lubrication intervals for ball bearings (horizontal mounting).

5. Mounting Forms

WGOST motors are supplied, as standard, in the B3T foot configuration, with the terminal box on top.



Figure 8 - B3T mounting

The mounting configuration for the WGOST motor lines comply with IEC 60034-7 standard. Standard mounting forms and their variations are shown in Table 6. After the designation, a characteristic letter is used to define the terminal box position. So, the mounting code IM B3 can be seen in WEG documents as detailed below (without IM code).

B3L - terminal box on left hand side of the motor frame

B3T - terminal box on top of the motor frame

B3R - terminal box on right hand side of the motor frame

Note: The terminal box position is defined viewing the motor from the shaft end. Mounting forms and their variations are indicated in Table 6.









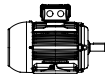

Basic mountings	Other type of mounting			
IM B3	IM V5	IM V6	IM B14	IM V18
IM 1001	IM 1011	IM 1031	IM 3601	IM 3611
				
IM B35	IM V15	IM B5	IM V1	IM V3
IM 2001	IM 2011	IM 3001	IM 3011	IM 3031
				
IM B34	IM V17	IM V19		
IM 2101	IM 2111	IM 3631		
				

Table 6 - Mountings configurations

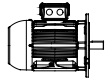
* Non-defined mountings by IEC 60034-7.

Important:

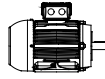
1. For motors mounted vertically shaft down fitting of a drip cover / impact canopy is recommended to prevent ingress of small objects into the fan cover.
2. For motors mounted vertically with shaft up and installed in environments containing liquids, the use of a rubber slinger is recommended to prevent the ingress of liquid into the motor through the shaft.

5.1 Painting



Figure 9 - WEG internal painting plan

The standard painting plans utilized on WGOST motors meet the atmospheric corrosive category “C2” as indicated in the DIN EN ISO 12944-2 standard. They are designed for use on motors installed in normal environments, slightly severe, sheltered or non-sheltered, for industrial use, with low relative humidity, normal temperature variations and the presence of SO₂.

Motor frame sizes 71 to 132 utilize WEG internal painting plan 207A (semi-matt), which consists of:

Primer: One coat of red oxide, alkyd based primer, with minimum thickness of 20 μm.

Finishing: One coat of styrenated alkyd based synthetic enamel paint, with minimum thickness of 30 μm.

And, motors in frame sizes 160-355 utilise the WEG internal paint plan 203A (semi-gloss):

Primer: One coat of red oxide, alkyd based primer, with minimum dry coat thickness of 20 μm.

Finishing: One coat of alkyd based synthetic enamel paint, with minimum dry coat thickness of 40 μm.

Note:

These painting plans are not recommended for direct exposure to acid steam, alkalis, solvents and salty environments.

Alternative painting plans are available on request, which are suitable to guarantee additional protection in aggressive environments, either protected or unprotected.

6. Ambient and Altitude

Unless otherwise specified, the rated outputs shown in the electrical data tables within this catalogue refer to continuous duty operation S1, as per IEC 60034-1 and under the following conditions:

- ambient temperature range -45 °C to 40 °C
- altitudes up to 1000 metres above sea level

For operating temperatures and altitudes differing from those above, the factors indicated in Table 7 must be applied to the nominal motor power rating in order to determine the derated output (Pmax).

$P_{max} = P_{nom} \times \text{correction factor}$

T (°C)	Altitude (m)									
	1000	1500	2000	2500	3000	3500	4000	4500	5000	
10							0,97	0,92	0,88	
15						0,98	0,94	0,90	0,86	
20					1,00	0,95	0,91	0,87	0,83	
25				1,00	0,95	0,93	0,89	0,85	0,81	
30			1,00	0,96	0,92	0,90	0,86	0,82	0,78	
35		1,00	0,95	0,93	0,90	0,88	0,84	0,80	0,75	
40	1,00	0,97	0,94	0,90	0,86	0,82	0,80	0,76	0,71	
45	0,95	0,92	0,90	0,88	0,85	0,81	0,78	0,74	0,69	
50	0,92	0,90	0,87	0,85	0,82	0,80	0,77	0,72	0,67	
55	0,88	0,85	0,83	0,81	0,78	0,76	0,73	0,70	0,65	
60	0,83	0,82	0,80	0,77	0,75	0,73	0,70	0,67	0,62	
65	0,79	0,76	0,74	0,72	0,70	0,68	0,66	0,62	0,58	
70	0,74	0,71	0,69	0,67	0,66	0,64	0,62	0,58	0,53	
75	0,70	0,68	0,66	0,64	0,62	0,60	0,58	0,53	0,49	
80	0,65	0,64	0,62	0,60	0,58	0,56	0,55	0,48	0,44	

Table 7 - Correction factors for altitude and ambient temperature

7. Insulation & Temperature Rise

WGOST motors are supplied with class F or H insulation. Figure 10 shows the safety margins per thermal class.

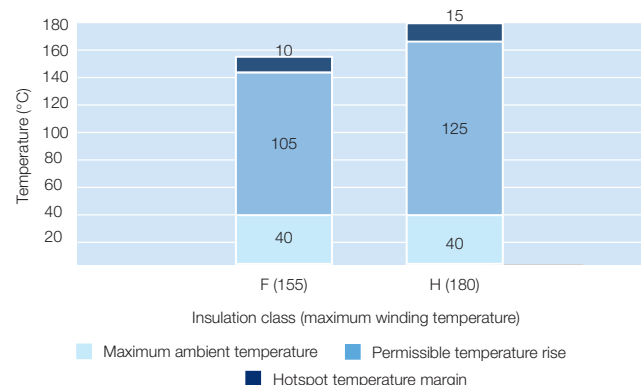

Figure 10 - Safety margins per thermal class.

Bearing lubrication intervals will change under operating conditions other than 40 °C maximum ambient temperature and 1000 metres above sea level. Contact WEG for further information.

All WGOST motors are wound with the insulation system which consists of enamelled wire impregnated with solvent free resin which protects motors at temperatures up to 200 °C.

7.1 Space Heaters

The use of space heaters is recommended in two situations:

- Motors installed in environments with relative air humidity up to 95%, in which the motor may remain idle for periods greater than 24 hours;
- Motors installed in environments with relative air humidity greater than 95%, regardless of the operating schedule. It should be highlighted that in this situation it is strongly recommended that an epoxy painting, more commonly known as tropicalization, is applied to the internal components of the motor.

The supply voltage for space heaters must be defined by the Customer. For all frame sizes, WGOST motors can be provided with space heaters suitable for 110-127 V, 220-240 V and 380-480 V. As an option, dual voltage heaters of 110-127 / 220-240 V can be supplied for motor frame sizes 112 to 355M/L, through reconnection of the heater cables inside the terminal box.

The power rating and number of space heaters fitted depends on the size of the motor as indicated in Table 8 below:

Frame	Quantities	Total power rated (W)
71 to 80	1	7,5
90 and 100	1	11
112	2	22
132 and 160	2	30
180 and 200	2	38
225 and 250	2	56
280 and 315	2	140
355	2	174

Table 8 - Power and quantity of space heaters

8. Motor Protections

Protections available for the WGOST motor line can be classified as follows:

- Based on operating temperature
- Based on operating current

8.1 Protection Based on Operating Temperature

Continuous duty motors must be protected from overload either by a device integrated into the motor or via an independent protection system, usually a thermal relay with rated or setting current, equal to or below the value obtained when multiplying the power supply rated current (I_n), as per Table 9.

Service factor	Relay setting current
1,0 up to 1,15	$I_n \times S.F.$
$\geq 1,15$	$(I_n \times S.F.) - 5\%$

Table 9 - Relay setting current referred to service factor

8.1.1 Pt-100



Figure 11 - Pt-100

These are temperature detectors with operating principle based on the properties that some materials vary the electric resistance with the variation in temperature (usually platinum, nickel or copper). They are also fitted with calibrated resistances that vary linearly with temperature, allowing continuous reading of motor operating temperature through a monitoring display, with high precision rate and response sensitivity.

The same detector can serve as alarm (with operation above the regular operating temperature) and trip (usually set up for the maximum temperature of the insulation class).

8.1.2 Thermistor (PTC)



Figure 12 - Thermistor (PTC)

A thermistor is a non-linear resistance temperature detector, made from semi-conductor material. Each specific thermistor has its own unique resistance vs. temperature characteristic i.e. they have one pre-set, non-adjustable tripping point.

PTC (positive temperature coefficient) thermistors have a resistance that increases dramatically at its defined tripping temperature. This sudden variation in resistance blocks the PTC current which causes the output relay to operate and the main circuit to switch off.

Thermistors are compact, do not wear, and feature faster response times when compared to other types of thermal protectors, although they do not allow continuous monitoring of motor operating temperature.

Together with their electronic circuits, these thermistors provide full protection against overheating caused by overload, under or overvoltage or frequent reversing operations.

Where thermistor protection is required to provide both alarm and trip operation, it is necessary for each phase of the motor winding to be equipped with two sets of appropriately rated thermistors.

WEG Automation offers a range of electronic relays 'RPW' intended specifically to read the PTC signal and operate its output relay. For further information please visit the website www.weg.net.

8.2 Protection Based on Operating Current

Overloads are processes which usually see the temperature increase gradually. To overcome this problem, the thermal protectors described in item 8.1 are quite suitable. However, the only way to protect motors against short-circuit currents is the application of fuses. This type of protection depends directly on the motor current and is highly effective in cases of locked rotor.

WEG Automation supplies a range of fuses in versions D and NH. Visit the website www.weg.net for further information.

9. Variable Speed Drive Application

9.1 Influence of the VSD on the Motor Temperature

Motors operating with frequency inverters may present a higher temperature rise than when operating under sinusoidal supply. This occurs due to the combined effects of the loss increase resulting from the PWM harmonics and the reduction in ventilation experienced by self-ventilated motors when operating at low frequencies. There are basically two solutions to avoid excessive overheating of the motor in VSD applications:

- Torque derating (oversizing of the self-ventilated motor frame size);
- Optimal Flux Solution (exclusive to applications where both motor and drive are WEG).

9.1.1 Torque Derating Criteria

In order to maintain the temperature rise of WEG motors within acceptable levels, when supplied by VSD, the speed range-related loadability limits established in Figure 13 (for operation under constant flux condition).

Notes:

- 1 - These derating curves relate to the motor thermal capability only and do not concern the insulation class. Speed regulation will depend on VSD mode of operation and proper adjustment.
- 2 - Torque derating is usually necessary when the motor is required to drive constant torque loads (e.g. screw compressors, conveyors, extruders, etc.). For squared torque loads, such as pumps and fans, no torque derating is normally required.

9.1.2 Constant Flux Condition

Applicable when the motor is supplied by any commercial drive operating with any control scheme other than the Optimal Flux available in WEG drives.

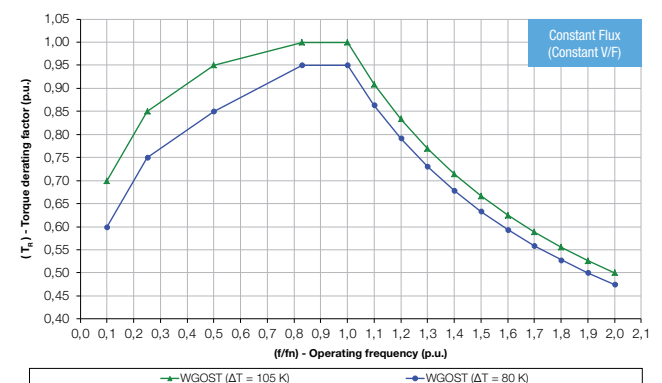

Figure 13 - Derating curves for constant flux condition

10. Construction Features

Frame		71	80	90	100	112	132	160	180	200	225	250	280	315S/M	355M/L	
Mechanical features																
Mounting form		B3T (options are available as per section 5)														
Frame material		FC-200 (EN GJL 200) cast iron														
Degree of protection		IP55														
Grounding		Simple grounding - one earth terminal inside the terminal box										Double grounding - one earth terminal inside the terminal box and another on the motor frame				
Cooling method		Totally enclosed fan cooled - IC411														
Fan material		Polypropylene														
		Polypropylene														
Fan cover material		Steel							FC-200 (EN GJL 200) cast iron							
Endshields material		FC-200 (EN GJL 200) cast iron														
Drain hole		Rubber drain plug														
Bearings	Drive end side	2p	6204-Z-C3	6205-Z-C3	6205-Z-C3	6206-Z-C3	6307-Z-C3	6308-Z-C3	6309-Z-C3	6311-Z-C3	6312-Z-C3	6314-C3	6314-C3	6316-C3	6316-C3	6219-C3
		4 - 8p							6311-Z-C3	6312-Z-C3	6314-Z-C3		6316-C3	6319-C3	6319-C3	6322-C3
	Non drive end side	2p	6202-Z-C3	6203-Z-C3	6204-Z-C3	6205-Z-C3	6206-Z-C3	6207-Z-C3	6209-Z-C3	6211-Z-C3	6212-Z-C3		6314-C3	6314-C3	6314-C3	6314-C3
		4 - 8p											6316-C3	6316-C3	6316-C3	6319-C3
Locking		Without bearing cap and with spring washer at NDE							DE bearing locked with inner bearing cap and fitted with wave washer in the NDE bearing			DE bearing locked with inner and outer bearing caps and fitted with pre-load springs in the NDE bearing				
Shaft Seal		V' Ring														
Lubrication	Type of grease	Mobiltemp SHC 32														
	Grease fitting	Without grease fitting										With grease fitting				
Terminal block		BMC terminal block - 6 pins														
Terminal box material		FC-200 (EN GJL 200) cast iron														
Cable entries	Main	Size	2xM20x1,5		2xM25x1,5		2xM32x1,5		2xM40x1,5		2xM50x1,5		2 x M63 x 1.5		2xM80x2 (removable gland plate)	
	Threaded plug		Threaded plug for transport and storage; cable gland as optional													
	Accessory	Size	1xM20x1,5 lateral threaded hole when fitted with accessories													
Shaft	Material		AISI 1040/45													AISI 4140
	DE Threaded hole	2p	M6	M8	M8	M10	M12	M12	M16	M16	M20	M20	M20	M20	M20	M20
		4 - 8p								M20					M24	M24
Direction of rotation		Bidirectional														
Vibration level		Grade A														
Nameplate material		Stainless steel AISI 304														
Painting	Type	207 A							203 A							
	Colour	RAL 7024														
Electrical features																
Design		N														
Voltage / Frequency		220/380 - 6 cables									380/660 - 6 cables					
Winding	Impregnation	Dip and bake														
	Insulation class	F (DT 105K)														
Service factor		1,00														
Rotor		Aluminium die cast														
Thermal protection		Without thermal protection									Thermistor PTC for tripping at 155 °C					

11. Electrical Data

WGOST - IE1 Efficiency

Output		Frame	Full Load Torque (Nm)	Locked Rotor Current II/In	Locked Rotor Torque TI/Tn	Break-down Torque Tb/Tn	Inertia J (kgm ²)	Allowable locked rotor time (s)		Weight (kg)	Sound dB(A)	Rated speed (rpm)	% of full load						Voltage (V)	Full load current In (A)
kW	HP							Efficiency					Power Factor							
								50	75				100	50	75	100				
II pole - 3000 rpm - 50 Hz																				
0,37	0,5	71	1,24	4,4	2,2	2,6	0,0003	12	26	10,0	56	2845	58,8	63,9	63,9	0,51	0,65	0,76	220	2,00
0,55	0,75	71	1,87	4,6	1,9	2,4	0,0004	10	22	11,0	56	2810	69,0	69,0	69,0	0,63	0,77	0,86	220	2,43
0,75	1	71	2,53	5,3	3,7	3,6	0,0005	10	22	12,0	56	2830	69,8	72,1	72,1	0,51	0,66	0,76	220	3,59
1,1	1,5	L71	3,77	5,5	3,8	3,3	0,0006	11	24	13,0	56	2790	74,5	75,0	75,0	0,57	0,71	0,82	220	4,69
1,5	2	L80	5,06	5,9	3	3	0,0010	8	18	16,0	59	2835	76,9	77,2	77,2	0,60	0,72	0,81	220	6,3
2,2	3	L80	7,59	6,0	4,2	3	0,0014	9	20	18,0	59	2770	79,0	79,7	79,7	0,62	0,74	0,82	220	8,83
3	4	90L	10,0	6,5	3,9	3,7	0,0027	7	15	24,0	64	2865	79,2	81,5	81,5	0,48	0,62	0,72	220	13,4
4	5,5	100S	13,2	8,5	3,6	3,9	0,0064	9	20	33,0	67	2905	80,9	83,1	83,1	0,63	0,77	0,85	220	14,9
5,5	7,5	L100L	18,2	8,0	3	3,2	0,0080	6	13	36,0	67	2880	84,7	84,7	84,7	0,75	0,85	0,89	220	19,1
7,5	10	L112M	24,9	7,7	3,2	3,4	0,0101	10	22	47,0	64	2880	85,5	86,0	86,0	0,69	0,79	0,85	220	26,9
11	15	132M	36,0	8,0	3	3,4	0,0342	7	15	85,0	68	2920	85,6	87,6	87,6	0,71	0,81	0,86	220	38,3
15	20	160S	48,6	8,9	3,4	4,3	0,0516	7	15	116	67	2950	87,3	88,7	88,7	0,56	0,70	0,78	220	56,9
18,5	25	160M	60,0	8,3	3,3	3,9	0,0626	7	15	127	67	2945	89,3	89,3	89,3	0,68	0,80	0,85	220	64
22	30	180S	71,3	7,9	3,3	3,5	0,0906	12	26	163	67	2950	89,9	89,9	89,9	0,63	0,75	0,82	220	78,3
30	40	180M	97,2	8,4	3,1	3,1	0,1192	11	24	184	67	2950	90,7	90,7	90,7	0,71	0,81	0,85	220	102
37	50	200M	119	7,4	3	3,1	0,1788	14	31	234	72	2960	91,1	91,2	91,2	0,66	0,77	0,82	380	75,2
45	60	200L	145	8,5	3,4	3,5	0,2204	10	22	258	72	2965	91,4	91,7	91,7	0,62	0,74	0,80	380	93,2
55	75	225S/M	177	8,4	2,7	3,5	0,2731	10	22	358	75	2965	92,1	92,1	92,1	0,69	0,79	0,84	380	108
75	100	250S/M	242	8,9	3,1	3,5	0,4245	11	24	447	75	2960	92,7	92,7	92,7	0,73	0,82	0,86	380	143
90	125	250S/M	291	8,9	3,1	3,3	0,5434	11	24	499	75	2960	93,0	93,0	93,0	0,79	0,86	0,88	380	167
110	150	280S/M	353	8,3	2,2	3,4	0,9776	17	37	646	77	2977	93,3	93,3	93,3	0,67	0,77	0,82	380	218
132	175	280S/M	424	8,4	2,2	3,3	1,16	17	37	697	77	2976	93,5	93,5	93,5	0,73	0,82	0,85	380	252
160	220	315S/M	514	7,3	2,1	3	1,86	26	57	934	77	2977	93,8	93,8	93,8	0,74	0,82	0,86	380	301
200	270	315S/M	641	8,7	2,8	3,6	2,66	20	44	1079	77	2982	94,0	94,0	94,0	0,79	0,86	0,88	380	367
250	340	315S/M	801	8,9	3	3,5	3,42	19	42	1228	77	2982	94,0	94,0	94,0	0,83	0,88	0,90	380	449
315	430	355M/L	1007	9,0	2,9	4,1	4,72	19	42	1605	80	2988	94,0	94,0	94,0	0,68	0,79	0,84	380	606
355	480	355M/L	1136	8,8	2,6	3,5	5,25	20	44	1698	80	2987	94,0	94,0	94,0	0,79	0,86	0,88	380	652
IV pole - 1500 rpm - 50 Hz																				
0,37	0,5	71	2,55	3,8	2,1	2,1	0,0007	19	42	11,0	43	1385	58,2	66,0	66,0	0,50	0,60	0,73	220	2,02
0,55	0,75	71	3,82	4,2	3,4	2,8	0,0009	28	62	12,0	43	1375	67,5	70,0	70,0	0,44	0,57	0,67	220	3,08
0,75	1	L71	5,29	4,7	3,2	2,9	0,0011	29	64	13,0	43	1355	72,1	72,1	72,1	0,50	0,60	0,70	220	3,90
1,1	1,5	80	7,51	5,5	2,7	2,7	0,0032	8	18	16,0	44	1400	73,4	75,0	75,0	0,57	0,70	0,80	220	4,81
1,5	2	L80	10,3	5,5	2,9	2,6	0,0039	6	13	18,0	44	1385	75,5	77,2	77,2	0,59	0,73	0,82	220	6,22
2,2	3	90L	14,7	6,6	2,7	2,7	0,0066	6	13	24,0	49	1430	79,0	79,7	79,7	0,57	0,71	0,80	220	9,06
3	4	L100S	20,0	6,9	2,8	2,8	0,0119	6	13	34,0	53	1435	80,7	81,5	81,5	0,53	0,68	0,77	220	12,5
4	5,5	L100L	26,9	7,0	3,9	3,3	0,0119	10	22	37,0	53	1420	83,1	83,1	83,1	0,54	0,68	0,77	220	16,4
5,5	7,5	112M	36,5	6,7	2,7	2,8	0,0180	9	20	45,0	56	1440	84,0	84,7	84,7	0,55	0,69	0,77	220	22,1
7,5	10	132S	49,1	7,0	2	2,9	0,0751	5	11	69,0	60	1460	82,0	86,0	86,0	0,63	0,76	0,83	220	27,6
11	15	132M/L	71,7	7,7	2,1	3	0,0788	4	9	121	60	1465	86,5	87,6	87,6	0,67	0,78	0,84	220	39,2
15	20	160S	97,2	7,7	2,7	2,9	0,1258	7	15	131	61	1475	88,0	88,7	88,7	0,64	0,76	0,83	220	53,5
18,5	25	160M	120	7,2	2,7	3,1	0,1603	5	11	144	61	1475	88,3	89,3	89,3	0,62	0,74	0,80	220	68,0
22	30	180S	143	7,1	2,9	3	0,1661	12	26	167	61	1465	89,9	89,9	89,9	0,65	0,77	0,82	220	78,3
30	40	180M	196	7,7	3,2	3,2	0,2393	10	22	191	61	1465	90,3	90,7	90,7	0,61	0,73	0,80	220	109
37	50	200M	240	7,5	2,9	3	0,3736	13	29	260	65	1475	91,2	91,2	91,2	0,67	0,78	0,83	380	74,3
45	60	200L	291	8,4	3,6	3,6	0,4002	7	15	270	65	1480	91,3	91,7	91,7	0,53	0,67	0,75	380	99,4
55	75	225S/M	356	6,8	2,4	2,6	0,6903	17	37	397	68	1475	91,5	92,1	92,1	0,77	0,84	0,87	380	104
75	100	250S/M	486	6,7	2,3	2,4	1,14	13	29	504	68	1475	92,7	92,7	92,7	0,78	0,85	0,87	380	141
90	125	250S/M	581	7,9	3	3,1	1,21	9	20	518	68	1480	93,0	93,0	93,0	0,72	0,81	0,85	380	173
110	150	280S/M	708	7,2	2,2	2,7	1,79	11	24	636	71	1485	93,3	93,3	93,3	0,65	0,75	0,81	380	221
132	175	280S/M	849	8,3	2,8	3,1	2,33	13	29	728	71	1485	93,5	93,5	93,5	0,69	0,79	0,83	380	258
160	220	315S/M	1026	7,3	2,6	2,8	3,01	21	46	952	71	1490	93,8	93,8	93,8	0,69	0,79	0,83	380	312
200	270	315S/M	1283	7,8	2,8	3	3,77	18	40	1054	71	1490	94,0	94,0	94,0	0,67	0,77	0,82	380	394
250	340	355M/L	1604	6,0	2	2,3	7,16	20	44	1492	76	1489	94,0	94,0	94,0	0,68	0,79	0,83	380	487
315	430	355M/L	2020	6,5	2,3	2,6	8,02	17	37	1582	76	1490	94,0	94,0	94,0	0,69	0,79	0,82	380	621
355	480	355M/L	2277	6,5	2,3	2,4	10,7	24	53	1856	76	1490	94,0	94,0	94,0	0,65	0,76	0,82	380	700

Notes:

(1) Efficiency values are given according to GOST IEC 60034-30-1-2016.

WGOST - IE1 Efficiency

Output		Frame	Full Load Torque (Nm)	Locked Rotor Current I/In	Locked Rotor Torque TI/Tn	Break-down Torque Tb/Tn	Inertia J (kgm ²)	Allowable locked rotor time (s)		Weight (kg)	Sound dB(A)	Rated speed (rpm)	% of full load						Voltage (V)	Full load current In (A)
								Hot	Cold				Efficiency			Power Factor				
													50	75	100	50	75	100		
VI pole - 1000 rpm - 50 Hz																				
0,37	0,5	80	3,80	3,4	2,2	2,3	0,0025	24	53	15,0	43	930	59,0	59,7	59,7	0,49	0,62	0,72	220	2,26
0,55	0,75	80	5,71	3,7	2,3	2,1	0,0030	18	40	16,0	43	920	64,5	65,8	65,8	0,51	0,65	0,75	220	2,92
0,75	1	L80	7,79	4,5	2,8	2,5	0,0037	13	29	17,0	43	920	65,2	70,0	70,0	0,50	0,62	0,72	220	3,91
1,1	1,5	90L	11,2	4,5	2,5	2,1	0,0066	17	37	24,0	45	935	72,9	72,9	72,9	0,54	0,68	0,76	220	5,21
1,5	2	L90L	15,4	4,7	2,7	2,3	0,0077	9	20	25,0	45	930	74,0	75,2	75,2	0,46	0,62	0,70	220	7,48
2,2	3	L100L	22,0	5,2	2,6	2,7	0,0176	9	20	35,0	44	955	71,6	77,7	77,7	0,43	0,56	0,66	220	11,3
3	4	112M	30,2	5,5	2,6	2,6	0,0257	12	26	45,0	49	950	79,0	79,7	79,7	0,51	0,64	0,72	220	13,7
4	5,5	L112M	39,6	6,5	3,9	3,8	0,0293	14	31	48,0	49	965	77,5	81,4	81,4	0,45	0,55	0,66	220	19,5
5,5	7,5	132S	55,0	6,0	2,3	2,3	0,0643	28	62	70,0	53	955	83,1	83,1	83,1	0,57	0,68	0,75	220	23,2
7,5	10	132M/L	74,3	7,0	2,8	2,8	0,0871	18	40	95,0	53	965	84,6	84,7	84,7	0,51	0,63	0,71	220	32,7
11	15	160S	108	6,3	3	3,2	0,1580	11	24	125	57	975	85,4	86,4	86,4	0,52	0,66	0,74	220	45,2
15	20	L160M	147	7,0	3,3	3,4	0,2195	9	20	148	57	975	85,0	87,7	87,7	0,56	0,68	0,76	220	59,1
18,5	25	180M	180	8,4	3,2	3,7	0,2958	6	13	176	56	980	87,9	88,6	88,6	0,56	0,70	0,78	220	70,3
22	30	200M	213	6,6	2,9	3,3	0,3686	10	22	224	60	985	85,6	88,2	89,2	0,45	0,59	0,68	380	55,1
30	40	200L	292	6,3	2,5	2,7	0,4905	11	24	257	60	980	90,0	90,2	90,2	0,59	0,71	0,78	380	64,8
37	50	225S/M	361	6,9	2,6	2,8	0,7192	13	29	346	63	980	90,0	90,8	90,8	0,66	0,77	0,82	380	75,5
45	60	250S/M	437	7,1	2,8	2,9	1,01	12	26	410	64	985	91,4	91,4	91,4	0,60	0,73	0,79	380	94,7
55	75	250S/M	534	7,2	2,9	3,1	1,23	11	24	449	64	985	90,0	91,9	91,9	0,58	0,71	0,78	380	117
75	100	280S/M	727	6,4	2,2	2,5	2,79	18	40	659	65	986	92,0	92,6	92,6	0,65	0,75	0,80	380	154
90	125	280S/M	870	7,5	2,7	2,9	3,03	12	26	684	65	988	92,9	92,9	92,9	0,61	0,73	0,78	380	189
110	150	315S/M	1061	6,7	2,3	2,7	4,70	19	42	920	67	991	93,3	93,3	93,3	0,58	0,71	0,77	380	233
132	175	315S/M	1271	7,3	2,6	3	5,79	17	37	1008	67	992	93,5	93,5	93,5	0,56	0,69	0,75	380	286
160	220	355M/L	1541	5,3	1,9	2,2	6,95	33	73	1306	73	992	93,8	93,8	93,8	0,65	0,75	0,79	380	328
200	270	355M/L	1926	5,2	1,8	2,2	7,41	31	68	1348	73	992	93,8	94,0	94,0	0,61	0,72	0,77	380	420
250	340	355M/L	2401	7,2	2,9	3,3	12,0	22	48	1693	73	995	93,0	94,0	94,0	0,48	0,61	0,69	380	586
315	430	355M/L	3034	5,5	2	2,2	13,9	26	57	1860	73	992	94,0	94,0	94,0	0,66	0,76	0,80	380	636
VIII pole - 750 rpm - 50 Hz																				
0,37	0,5	80	5,16	3,0	2,4	1,8	0,0034	24	53	16,0	42	685	46,7	49,7	49,7	0,43	0,54	0,66	220	2,96
0,55	0,75	90L	7,51	3,5	2,1	2	0,0058	40	88	22,0	44	700	55,5	56,1	56,1	0,44	0,56	0,66	220	3,9
0,75	1	L90L	10,4	3,6	1,9	1,7	0,0077	28	62	25,0	44	690	60,6	61,2	61,2	0,50	0,61	0,72	220	4,47
1,1	1,5	100L	14,9	3,6	1,5	1,7	0,0143	17	37	31,0	50	705	63,5	66,5	66,5	0,46	0,59	0,67	220	6,48
1,5	2	100L	20,6	3,9	1,9	1,8	0,0143	27	59	33,0	50	695	70,0	70,0	70,2	0,45	0,58	0,66	220	8,5
2,2	3	112M	30,5	4,3	2,5	2,3	0,0238	23	51	43,0	46	690	74,0	74,2	74,2	0,49	0,63	0,71	220	11
3	4	132S	40,4	6,1	2,4	2,7	0,0789	23	51	69,0	48	710	76,5	77,0	77,0	0,51	0,64	0,72	220	14,2
4	5,5	L132M	53,1	7,1	3,6	4	0,1036	13	29	92,0	48	720	75,5	79,2	79,2	0,39	0,52	0,62	220	21,4
5,5	7,5	160M	72,5	4,3	2	2,1	0,1141	17	37	107	51	725	80,5	81,4	81,4	0,52	0,65	0,73	220	24,3
7,5	10	160S	98,8	5,0	2,2	2,2	0,1492	19	42	122	51	725	82,5	83,1	83,1	0,51	0,62	0,70	220	33,8
11	15	L160M	145	5,3	2,6	2,6	0,2195	13	29	148	51	725	82,0	85,0	85,0	0,49	0,60	0,68	220	49,9
15	20	180M	198	6,6	2,5	2,7	0,3259	9	20	184	52	725	85,5	86,2	86,2	0,60	0,71	0,78	220	58,5
18,5	25	200M	242	4,3	1,8	2	0,4396	22	48	243	56	730	86,0	86,9	86,9	0,60	0,70	0,76	380	42,6
22	30	200L	288	5,0	2,1	2,2	0,4923	14	31	257	56	730	86,0	86,9	87,4	0,52	0,63	0,70	380	54,6
30	40	225S/M	390	7,6	2,6	2,1	0,7214	11	24	346	56	735	87,5	88,3	88,3	0,55	0,67	0,74	380	69,8
37	50	250S/M	488	6,5	1,8	2,3	1,29	14	31	453	56	725	88,0	88,8	88,8	0,69	0,79	0,83	380	76,3
45	60	250S/M	589	7,8	2,5	3,1	1,38	9	20	467	56	730	88,5	89,2	89,2	0,59	0,71	0,80	380	95,8
55	75	280S/M	713	5,0	1,5	1,9	2,71	25	55	642	59	737	89,0	89,7	89,7	0,64	0,74	0,79	380	118
75	100	280S/M	971	5,3	1,7	1,9	3,61	21	46	736	59	738	89,0	90,3	90,3	0,64	0,74	0,79	380	160
90	125	315S/M	1164	5,4	1,6	1,9	5,67	29	64	989	62	739	90,0	90,7	90,7	0,69	0,77	0,80	380	188
110	150	315S/M	1422	5,5	1,7	1,9	6,93	30	66	1092	62	739	90,5	91,1	91,1	0,67	0,76	0,81	380	226
132	175	355M/L	1698	5,7	1,5	2,3	8,27	24	53	1242	70	743	91,5	91,5	91,5	0,59	0,70	0,76	380	288
160	220	355M/L	2055	6,3	1,9	2,6	10,1	18	40	1352	70	744	91,0	91,9	91,9	0,51	0,64	0,71	380	373
200	270	355M/L	2572	6,3	1,7	2,5	13,8	20	44	1564	70	743	92,5	92,5	92,5	0,62	0,73	0,78	380	421
250	340	355M/L	3215	6,5	1,8	2,5	18,1	23	51	1825	70	743	92,5	92,5	92,5	0,63	0,74	0,79	380	520

Notes:

(1) Efficiency values are given according to GOST IEC 60034-30-1-2016.

12. Mechanical Data

12.1 Foot Mounted Motors, Terminal Box Top

12.1.1 Frames 71 to L132M/L

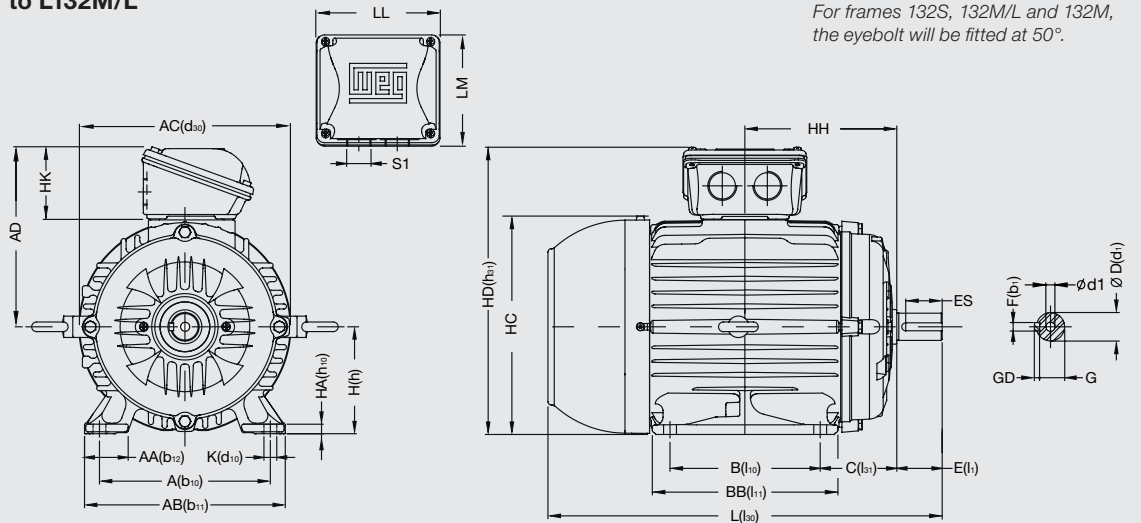

12.1.2 Frames 160M to 200L

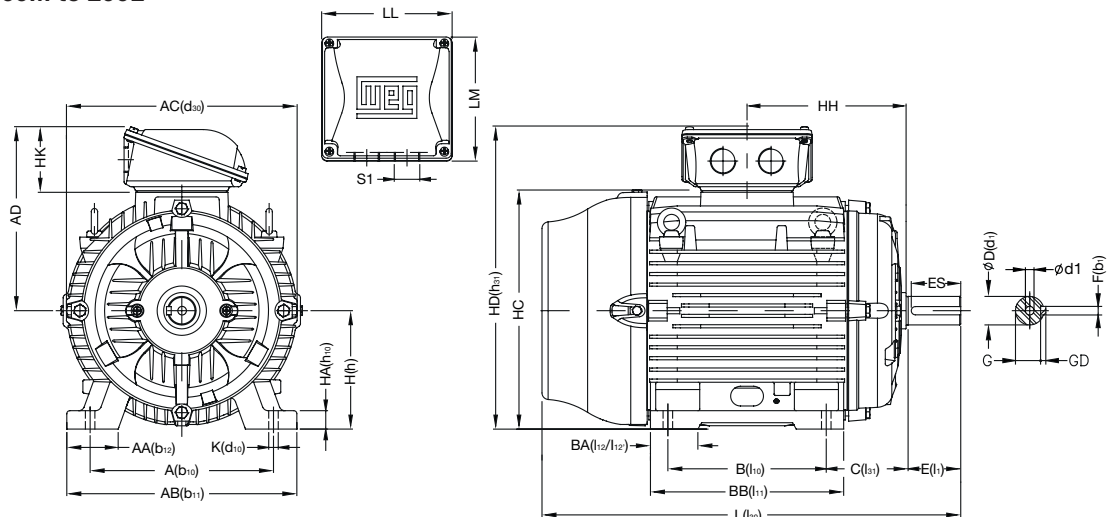

12.1.3 Frames 225 to 355M/L

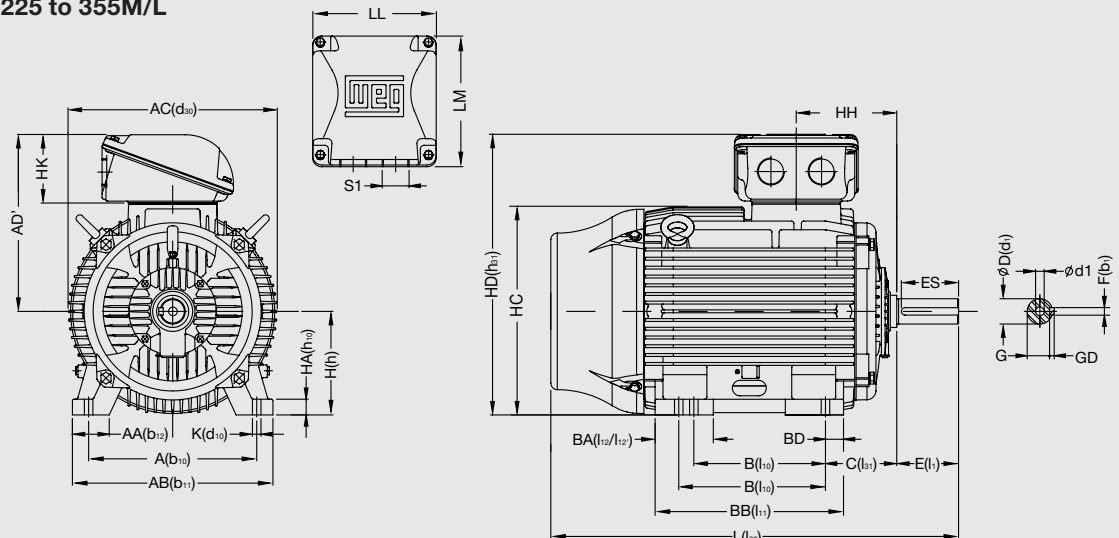

12.2 Flange Mounted Motors

12.2.1 “FF” Flange

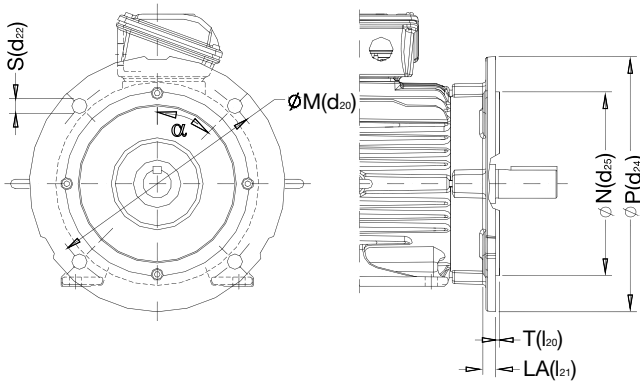

Frame	Flange	LA (l ₂₁)	M (d ₂₀)	N (d ₂₅)	P (d ₂₄)	S (d ₂₂)	T (l ₂₀)	α (α°)	N° of holes (n)
71	FF-165	9	165	130	200	11	3,5	45°	4
80									
90	FF-215	10	215	180	250	14	4		
100		12,5							
112	FF-265	11	265	230	300	19	5		
132	FF-300	15	300	250	350				
160		18							
180	FF-350	17,5	350	300	400				
200	FF-400	17	400	350	450				
225	FF-500	18	500	450	550				
250		20							
280	FF-600	16	600	550	660				
315		22							
355	FF-740	22	740	680	800			22,5°	8

*Only for motors fitted with air deflector in drive end side.

** Dimensions are in mm.

12.2.2 “FT” Flange (C-DIN)

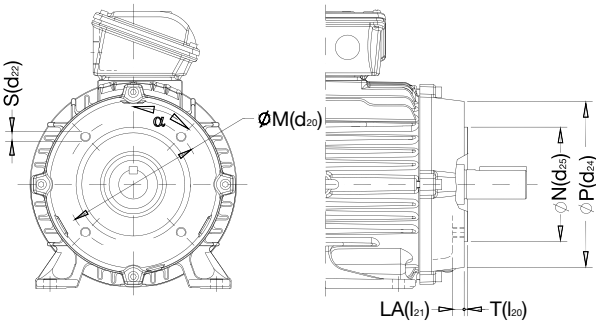

Frame	Flange		LA (l ₂₁)	M (d ₂₀)	N (d ₂₅)	P (d ₂₄)	S (d ₂₂)	T (l ₂₀)	α (α°)	N° of holes (n)	
	C-DIN	GOST									
71	C-105	FT-85	8	85	70	105	M6	2,5	45°	4	
	C-140	FT-115	12	115	95	140	M8	3			
80	C-120	FT-100	10,5	100	80	120	M6	3,5			
	C-160	FT-130	15	130	110	160	M8	3			
90	C-140	FT-115	11,5	115	95	140					
	C-160	FT-130	10,5	130	110	160					
100	C-160	FT-130	12	130	110	160		M10			3,5
	C-200	FT-165	15	165	130	200					
112	C-160	FT-130	13,5	130	110	160		M8			5
	C-200	FT-165	13	165	130	200		M10			
132	C-160	FT-130	19	130	110	160		M8			
	C-180	FT-150		150	120	180	M12				

* Dimensions are in mm.

13. Terminal Box Drawings

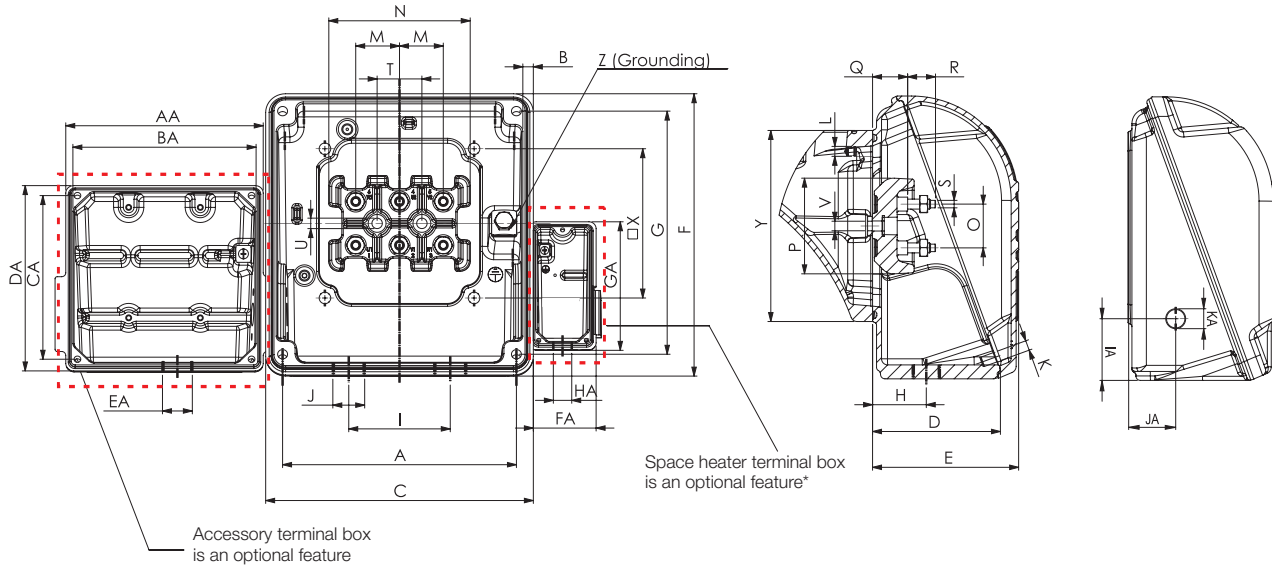

Frame	A	B	C	D	E	F	G	H	I	J	K	L	M	N	O	P	Q	R	S	T	U
71	90	3,5	108	51,5	59	98	85	27	42	2xM20x1,5	M5x0,8	M5x0,8	16	75	16	35	13,5	12	M4x0,7	20	5,8
80										2xM25x1,5											
90																					
100																					
112	117	2,5	140	71	80	133	117	36,5	54	2xM32x1,5	M6x1,0	M6x1,0	23		23	52	17	16	M5x0,8	23	6,5
132																					
160	175	4	198,5	90	101	190	175	46	84	2xM40x1,5	M8x1,25	M8x1,25	28	90	28	60	21,5	20,5	M6x1	28	6,6
180																					
200	204	4,5	230	107	119,5	220	204	59	94	2xM50x1,5	M10x1,5	M10x1,5	35	112	35	74	24	24	M8x1,25	35	9,5
225S/M																					
250S/M	235	12,5	269	133	153	285	260	71	110	2xM63x1,5	M12x1,75	M12x1,75	44	140	44	94	28	28	M10x1,5	45	10,5
280S/M																					
315S/M																					
355M/L																					
355M/L	365	14,5	404	202	220	436	390	97	200	2xM80x2	M14x2,0	M14x2,0	65	210	65	146	48	48	M16x2,0	65	

Frame	V	X	Y	Z	AA	BA	CA	DA	EA	FA	GA	HA	IA	JA	KA	Max number of connectors						
																Main	Accessories	Space heater				
71	M5x0,8	56	78	0,5-6 mm ²	109	90	85	98									4	16				
80			81																			
90			77																			
100			81																			
112			70																	107	2-10 mm ²	
132																				103		
160	M6x1,0	110	140	5,2-25 mm ²					M20x1,5	68		M20x1,5	47	40	M20x1,5	12		4				
180																						
200	M8x1,25	120	155	5,2-35 mm ²	139	117	117	133									16	26				
225S/M																				150	192	25-50 mm ²
250S/M																					197	
280S/M																				204	204	35-70 mm ²
315S/M																						
355M/L																				260	300	85-120 mm ²

Notes:
 (*) Dimension is applicable to top, right or left terminal box mounting
 (**) Space heater terminal box is a special feature for frame sizes 71 to 112.
 (***) Dimensions are in mm.

14. Packaging

14.1 Frames 71 to 132

WGOST motors in frames 71 to 132 are packaged in cardboard boxes, following the dimensions, weights and volumes of the Table 10 and Table 11.



Frame	External height (m)	External width (m)	External length (m)	Weight (kg)	Volume (m ³)
71 / L71	0,265	0,255	0,36	1,347	0,025
80 / L80					
90L / L90L	0,315	0,27	0,432	1,217	0,037
100S / L100S	0,325	0,27	0,455	1,804	0,04
100L	0,335	0,275	0,552	2,254	0,052
L100L	0,325	0,27	0,455	1,804	0,04
112M / L112M	0,415	0,335	0,595	3,43	0,08
132S / L132S	0,42	0,33	0,60	1,7	0,08
132M / L132M					
132M/L / L132M/L					

Table 10 - Cardboard box dimensions, weights and volumes for top mounting.

Frame	External height (m)	External width (m)	External length (m)	Weight (kg)	Volume (m ³)
71 / L71	0,215	0,285	0,355	0,71	0,021
80					
L80					
90L	0,23	0,315	0,398	0,8	0,029
L90L					
100S	0,26	0,35	0,455	1,685	0,042
L100S	0,255	0,34	0,540	2,021	0,047
100L	0,26	0,35	0,455	1,685	0,042
L100L	0,255	0,34	0,54	2,021	0,047
112M / L112M	0,315	0,375	0,52	2,379	0,06
132S / L132S	0,35	0,48	0,60	2,1	0,10
132M / L132M					
132M/L / L132M/L					

Note: Values to be added to the net motor weight.

Table 11 - Cardboard box dimensions, weights and volumes for side mounting.

14.2 Frames 160 to 355M/L

For frames 160 to 355M/L, the motors are packaged in wooden crates. Dimensions, weights and volumes are in Table 12 and Table 13.



Frame	External height (m)	External width (m)	External length (m)	Weight (kg)	Volume (m ³)
160	0,50	0,41	0,74	9,32	0,15
180	0,54	0,44	0,82	13,17	0,19
200	0,61	0,51	0,88	16,74	0,27
225S/M	0,90	0,85	1,15	49,3	0,88
250S/M			1,25	51,6	0,96
280S/M	1,13	1,05	1,40	77,5	1,34
315S/M			1,55	81,2	1,49
355M/L			1,73	127	2,40

Table 12 - Wooden crates dimensions, weights and volumes for top mounting.

Frame	External height (m)	External width (m)	External length (m)	Weight (kg)	Volume (m ³)
160	0,40	0,50	0,74	10,03	0,15
180	0,45	0,57	0,82	14,51	0,21
200	0,49	0,63	0,88	15,75	0,27
225S/M	0,78	0,85	1,15	49,7	0,88
250S/M	0,90	0,85	1,25	56,6	0,96
280S/M	1,0	0,95	1,40	72,1	1,33
315S/M	1,13	1,10	1,50	84,3	1,86
355M/L	1,20	1,19	1,72	146	2,46

Note: Values to be added to the net motor weight.

Table 13 - Wooden crates dimensions, weights and volumes for side mounting.

15. Spare Parts

15.1 General Information

The following information is required when purchasing of spare parts:

- Serial number and manufacturing date, both stamped in the nameplate
- Spare part description
- Codes shown are for reference only. Final codes of spare parts will depend on colour

15.1.1 Spare Parts Available 71-112

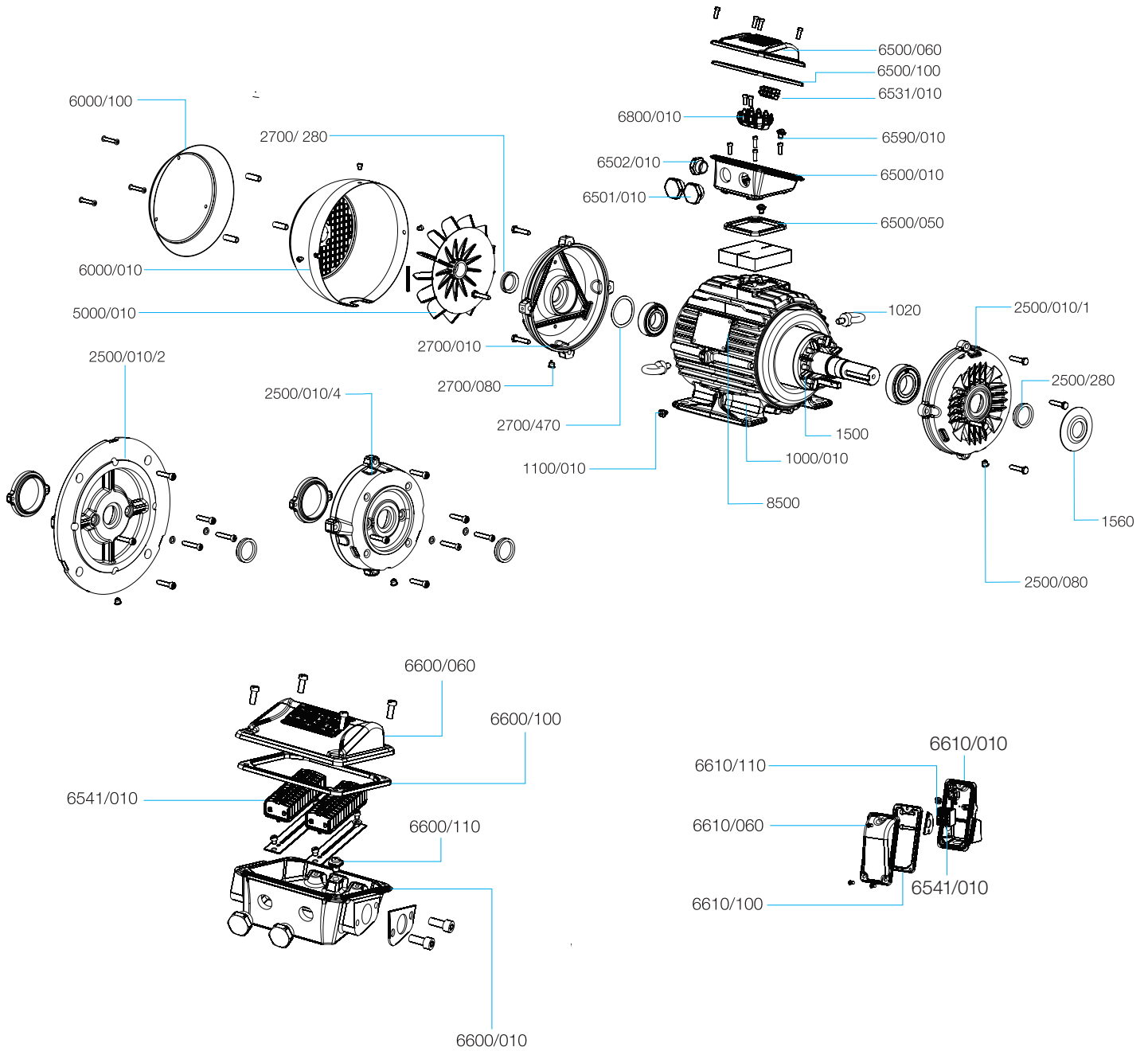

Motor component		Spare part	
Item	Description	Item	Composition
1000/010	Frame with wound stator	1000	Frame with wound stator
1020	Lifting eyebolt	1020	Lifting eyebolt
1100/010	Earthing terminal	1100	Earthing terminal
1500	Rotor, complete with shaft and key	1500	Rotor, complete with shaft and key
1560	Slinger	1560	Slinger (recommended for vertical shaft up applications, non-flange mounted)
2500/010/1	Endshield, drive end	2500/1	Endshield, drain plug, shaft seal, bolts and washers
2500/080	Drain plug, drive end		
2500/280	Shaft seal, drive end (1)		
2500/010/2	FF Flange	2500/2	FF Flange, drain plug, shaft seal, bolts and washers
2500/080	Drain plug, drive end		
2500/280	Shaft seal, drive end (1)		
2500/010/4	FT (C-DIN) Flange	2500/4	FT (C-DIN) Flange, drain plug, shaft seal, bolts and washers
2500/080	Drain plug, drive end		
2500/280	Shaft seal, drive end (1)		
2700/010	Endshield, non-drive end	2700	Endshield, drain plug, shaft seal, bolts and washers
2700/080	Drain plug, non-drive end		
2700/280	Shaft seal, non-drive end (1)		
2700/470	Wave washer for axial displacement		
5000/010	Cooling Fan	5000	Fan
6000/010	Fan cover	6000	Fan cover, bolts
		6050	Fan cover, drip cover and bolts
6000/100	Drip cover	6100	Drip cover, bolts
6500/010	Terminal box	6500	Terminal box complete with lid, gaskets (for lid and terminal box), plugs (for mains and accessories), earthing terminal, bolts and washers
6500/050	Terminal box gasket		
6500/060	Terminal box lid		
6500/100	Terminal box lid gasket		
6501/010	Terminal box plug for main leads		
6502/010	Terminal box plug for accessory leads		
6590/010	Terminal box earthing terminal		
6531/010	Accessory connector	6531	Accessory connector, mounting rail, bolts and washers
6541/010	Accessory connector	6541	Accessory connector, mounting rail, bolts and washers
6600/010	Accessories terminal box	6600	Accessory terminal box, complete with lid, gasket, plugs, earthing terminal, bolts and washers
6600/060	Accessories terminal box lid		
6600/100	Accessories terminal box lid gasket		
6600/110	Accessories terminal box earthing terminal		
6610/010	Space heater accessory terminal box	6610	Space heater accessory terminal box, complete with lid, gasket, plugs, earthing terminal, bolts and washers
6610/060	Space heater accessory terminal box lid		
6610/100	Space heater accessory terminal box lid gasket		
6610/110	Space heater accessory terminal box earthing terminal		
6800/010	Terminal block	6800	Terminal block, bolts and washers
8500	Main nameplate	8500	Main nameplate

Notes:

(1) As a spare part, the shaft sealing in the 71-112 range will be supplied as an integral part of the endshield kit.

15.1.2 Spare Parts Available 132-200

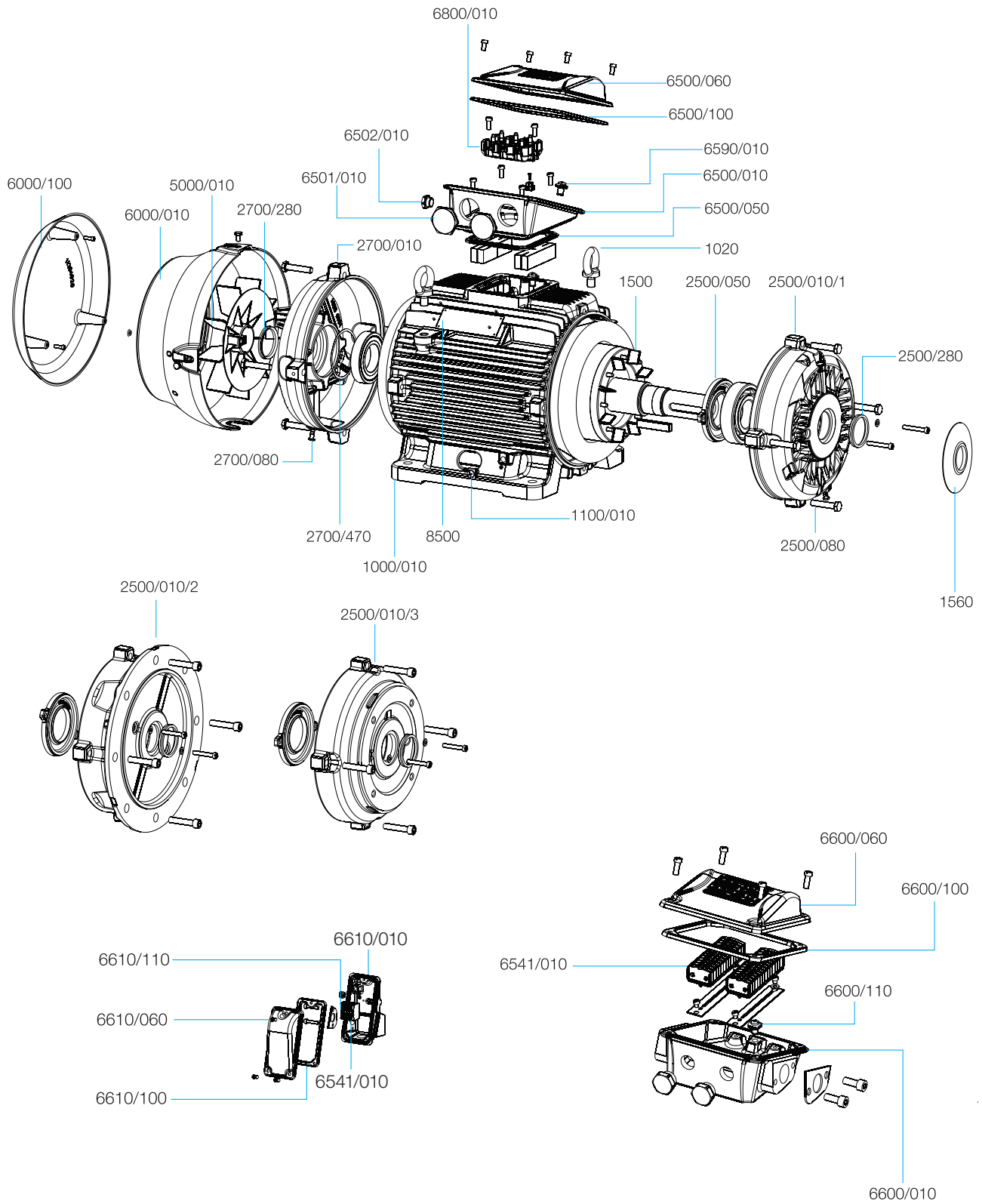

Motor component		Spare part	
Item	Description	Item	Composition
1000/010	Frame with wound stator	1000	Frame with wound stator
1020	Lifting eyebolt	1020	Lifting eyebolt
1100/010	Earthing terminal	1100	Earthing terminal
1500	Rotor, complete with shaft and key	1500	Rotor, complete with shaft and key
1560	Slinger	1560	Slinger (recommended for vertical shaft up applications, non-flange mounted)
2500/010/1	Endshield, drive end	2500/1	Endshield, bearing cap, drain plug, shaft seal, bolts and washers
2500/050	Bearing cap, internal, drive end		
2500/080	Drain plug, drive end		
2500/280	Shaft seal, drive end (1)		
2500/010/2	FF Flange	2500/2	FF Flange, drain plug, shaft seal, bolts and washers
2500/080	Drain plug, drive end		
2500/280	Shaft seal, drive end (1)		
2500/010/3	FT (C-DIN) Flange	2500/3	FT (C-DIN) Flange, drain plug, shaft seal, bolts and washers
2500/080	Drain plug, drive end		
2500/280	Shaft seal, drive end (1)		
2700/010	Endshield, non-drive end	2700	Endshield, drain plug, shaft seal, bolts and washers
2700/080	Drain plug, non-drive end		
2700/100	Grease nipple (with extensor pipe), non-drive end		
2700/280	Shaft seal, non-drive end (1)		
2700/470	Wave washer for axial displacement		
5000/010	Fan	5000	Fan
6000/010	Fan cover	6000	Fan cover, bolts
		6050	Fan cover, drip cover and bolts
6000/100	Drip cover	6100	Drip cover and bolts
6500/010	Terminal box	6500	Terminal box, complete with lid, gaskets (for lid and terminal box), plugs (for mains and accessories), earthing terminal, bolts and washers
6500/050	Terminal box gasket		
6500/060	Terminal box lid		
6500/100	Terminal box lid gasket		
6501/010	Terminal box plug for main leads		
6502/010	Terminal box plug for accessory leads		
6590/010	Terminal box earthing terminal		
6531/010	Accessory connector		
6541/010	Accessory connector	6541	Accessory connector, mounting rail, bolts and washers
6600/010	Accessories terminal box	6600	Accessory terminal box, complete with lid, gasket, plugs, earthing terminal, bolts and washers
6600/060	Accessories terminal box lid		
6600/100	Accessories terminal box lid gasket		
6600/110	Accessories terminal box earthing terminal		
6610/010	Space heater accessory terminal box	6610	Space heater accessory terminal box, complete with lid, gasket, plugs, earthing terminal, bolts and washers
6610/060	Space heater accessory terminal box lid		
6610/100	Space heater accessory terminal box lid gasket		
6610/110	Space heater accessory terminal box earthing terminal		
6800/010	Terminal block	6800	Terminal block, bolts and washers
8500	Main nameplate	8500	Main nameplate

Notes:

(1) As a spare part, the shaft seal in the 132-200 range will be supplied as an integral part of the endshield kit.

15.1.3 Spare Parts Available 225-355

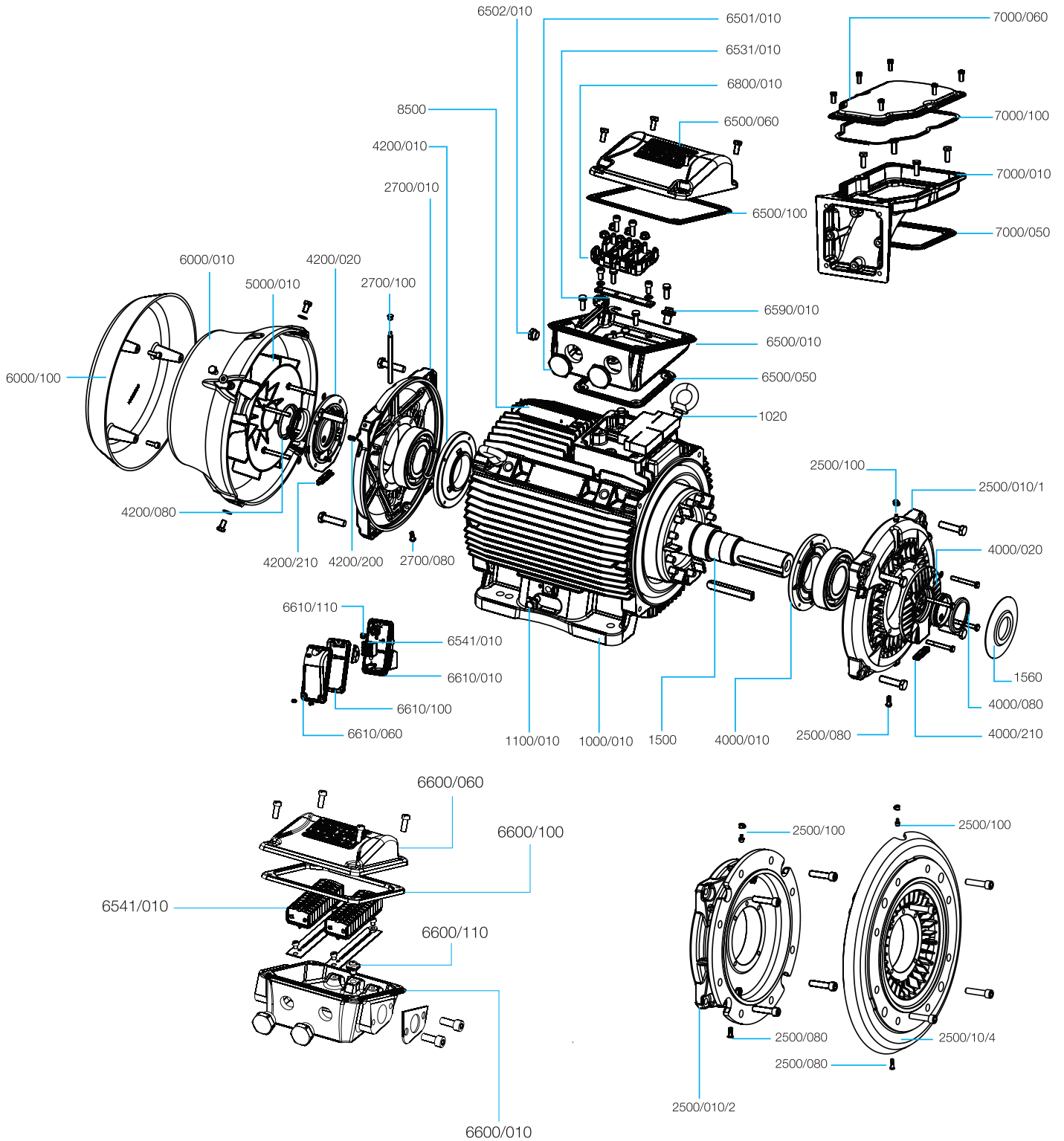

Motor component		Spare part			
Item	Description	Item	Composition		
1000/010	Frame with wound stator	1000	Frame with wound stator		
1020	Lifting eyebolt	1020	Lifting eyebolt		
1100/010	Earthing terminal	1100	Earthing terminal		
1500	Rotor, complete with shaft and key	1500	Rotor, complete with shaft and key		
1560	Slinger	1560	Slinger		
2500/010/1	Endshield, drive end	2500/1	Endshield, grease nipple, drain plug, bolts and washers		
2500/080	Drain plug, drive end				
2500/100	Grease nipple, drive end				
2500/010/2	FF Flange	2500/2	FF Flange, grease nipple, drain plug, bolts and washers		
2500/080	Drain plug, drive end				
2500/100	Grease nipple, drive end				
2700/010	Endshield, non-drive end	2700	Endshield, grease nipple with extensor pipe, drain plug, bolts and washers		
2700/080	Drain plug, non-drive end				
2700/100	Grease nipple (with extensor pipe), non-drive end				
4000/010	Bearing cap, internal, drive end	4000	Bearing cap (external and internal), shaft seal, grease relief, bolts and washers		
4000/020	Bearing cap, external, drive end				
4000/080	Shaft seal, drive end (1)				
4000/210	Grease relief	4200	Bearing cap (external and internal), shaft seal, grease relief with extensor pipe, pre-load springs, bolts and washers		
4200/010	Bearing cap, internal, non-drive end				
4200/020	Bearing cap, external, non-drive end				
4200/080	Shaft seal, non-drive end (1)				
4200/200	Pre-load springs for axial displacement				
4200/210	Grease relief				
5000/010	Fan	5000	Fan		
6000/010	Fan cover, cast iron	6000	Fan cover		
		6050	Fan cover and canopy		
6000/100	Canopy	6100	Canopy		
6500/010	Terminal box	6500	Terminal box, complete with lid, gaskets (for lid and terminal box), plugs (for mains and accessories), earthing terminal, bolts and washers		
6500/050	Terminal box gasket				
6500/060	Terminal box lid				
6500/100	Terminal box lid gasket				
6501/010	Terminal box plug for main leads				
6502/010	Terminal box plug for accessory leads				
6531/010	Accessory connector			6531	Accessory connector, mounting rail, bolts and washers
6541/010	Accessory connector	6541	Accessory connector, mounting rail, bolts and washers		
6590/010	Terminal box earthing terminal	6600	Accessory terminal box, complete with lid, gasket, plugs, earthing terminal, bolts and washers		
6600/010	Accessories terminal box				
6600/060	Accessories terminal box lid				
6600/100	Accessories terminal box lid gasket				
6600/110	Accessories terminal box earthing terminal	6610	Space heater accessory terminal box, complete with lid, gasket, plugs, earthing terminal, bolts and washers		
6610/010	Space heater accessory terminal box				
6610/060	Space heater accessory terminal box lid				
6610/100	Space heater accessory terminal box lid gasket				
6610/110	Space heater accessory terminal box earthing terminal	6800	Terminal block, mounting rail, bolts and washers		
6800/010	Terminal block				
7000/010	Terminal box adaptor base			7000	Terminal box adaptor for side mounted position, complete with lid, gaskets, bolts and washers
7000/050	Terminal box adaptor base gasket				
7000/060	Terminal box adaptor lid				
7000/100	Terminal box adaptor lid gasket				
8500	Main nameplate (2)	8500	Main nameplate		

Notes:

(1) As a spare part, the shaft sealing in the 225-355 range will be supplied as an integral part of the bearing cap kit.

(2) Main nameplate position will vary with terminal box configuration (top and side mounting).

The scope of WEG Group solutions
is not limited to products and solutions
presented in this catalogue.

To see our portfolio, contact us.

**For WEG's worldwide
operations visit our website**



www.weg.net



 +7 708 533 02 37

 sales-wca@weg.net

 Almaty - Kazakhstan

Cod: 50103350 | Rev: 06 | Date (m/y): 06/2025.

The values shown are subject to change without prior notice.
The information contained is reference values.